



Cartridge World[®]

Office Printing Survival Guide

10 Easy Ways to Simplify and Save



Why this guide?

If you're the person responsible for managing office printers, printer repairs, ordering supplies, managing supplies inventory and controlling print related costs while dealing with employee complaints – this guide is for you.

Normally the management of printers is a reactive activity that requires time and effort at the most inopportune times.

IT people often call printers “the Bain of IT” because they take time and focus away from higher level priorities.

Office printers, office printing, toner cartridges and printer service tend to be low priority for small businesses focused on growing their revenues and their profits – that's until you need something printed.

Did You Know?

- ✓ **39%** of all business processes **require paper documents**
- ✓ **10X** is the normal premium for printing in **color vs black & white**
- ✓ **10,000 pages per year** are printed by a typical office worker
- ✓ **90%** of organizations have had a **security breach** in the last year from hardcopy documents
- ✓ **30% cost reduction** is the usual savings by switching from Printer Brand to **Cartridge World toner**

Having an effective print strategy will help you save time and money. That's why we created this Office Printing Survival Guide with **10 Easy Steps to Simplify and Save**.

10 Step Office Printing Survival Guide!

- What to Do -

1.



Start with the right printer(s)

The wrong printer will often cost you more (upfront and in the future) and lead to inefficiencies around the office. But with the right printer, worker productivity can be boosted, with features like scanning, faxing and the ability to print remotely, otherwise known as “mobile printing”, to compliment your day-to-day tasks.

Here are 3 common printer selection mistakes:

- Overspending on a BIG copier or MFP when a printer can offer the same speed and performance.
- Underspending on a printer that forces you to buy printer cartridges that cost more than the printer itself!
- Buying or leasing a printer when you can avoid the hardware expense by simply agreeing to make your toner purchases with your local Cartridge World.

About our Why Buy a Printer? Program

Why buy or lease a printer when you can just **pay for the toner?**

Our exclusive approach eliminates traditional hardware and maintenance costs by providing your office with business class printer(s) and multifunction devices (MFPs) with all printer maintenance and on-site service included. In exchange for the use of our printers, all we ask is that you make your initial and ongoing toner cartridge purchases from us. It's that simple. Plus, our premium quality toner cartridges match original cartridge (OEM) performance and will also help you save up to 30% vs. OEM printer cartridges and big box store toner prices.

2.

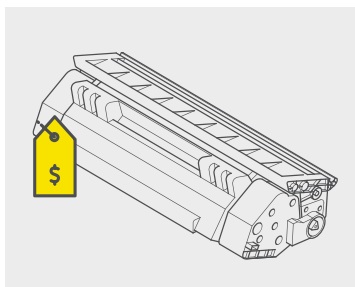

Don't get tricked into thinking you need to buy printer brand toner.

Printer manufactures want you to think that you must buy their toner. Their strategy of seeding businesses with low price printers and then making huge profits on premium priced toner cartridges is understood by seasoned buyers. If you haven't switched to an alternative brand of printer cartridges already, your local cartridge World can help you achieve the same great output quality and page yields with our premium quality alternative – and you'll save up to 30%.

3.

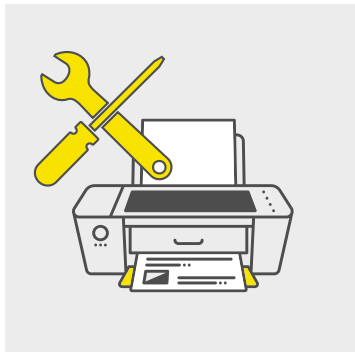

Outsource printer service so employees don't get distracted with printer issues.

Printers tend to break down at the worst time. Paper jamming, poor quality, error codes you don't understand and more. By outsourcing the repair and proactive maintenance of your printers to local service provider like Cartridge World, you and your people can stay focused on higher priority tasks while we take care of your printers for you. Save yourself the time and frustration, ask us to give you a quick quote on servicing the printers in your office – all makes and models.

4.



Communicate a print policy to staff with understood "printing rules" like a long-distance policy.

Think of the business equipment in your office that operates on a pay-for-use basis. Company cell phones, the mailing machine, gas pumps, and maybe even the coffee machine? If you have provided your staff with rules or guidelines for these devices, why not do the same with your office printers? Surprisingly, less than 10% of small to medium size businesses have communicated any rules or guidelines for office printing. Without rules, it's impossible to monitor and manage.

5.



Standardize on the same printer when possible to simplify supplies ordering.

Ordering toner cartridges and other consumables for different types of printers can be confusing, let alone frustrating when you need to know specific details for each printer make and model. Often, to avoid running out, some offices will order extra causing a stockpile effect that only ties up useable capital in toner cartridges. Progressive offices streamline supplies ordering and inventory by standardizing on the same printers or "family of printers" that use the same consumables. If you have a mix of printers in your office, you can also ask your local Cartridge World about our exclusive line of universal cartridges that can be used in more than one printer make/model.

6.

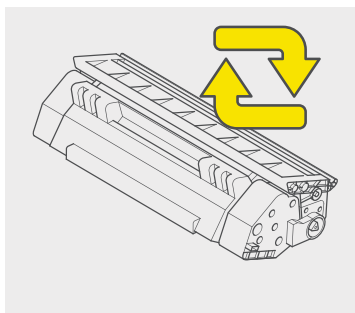

Set up "Proactive Toner Ordering" to avoid running out of toner.

It's now possible to have your printer communicate with your local Cartridge World before a toner cartridge or consumable part is required. Much like the "low fuel" indicator in your vehicle, new monitoring technology can identify the printer that's running low, it's location and have the right toner arrive before you run out. The benefits are less stress, less hassle, less inventory and less time wasted on last minute emergency purchases and rush delivery fees.

7.

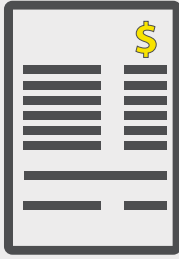

Centralize purchasing and simplify billing to one invoice for cost visibility and control.

A recent study by a printer manufacturer found that 37 – 41% of print related expenses tend to avoid formal purchasing approval. This was caused because multiple people or specific departments within organizations all have the authority to purchase printers and supplies that fall below a defined amount. Purchasing independently without leveraging the overall spend may be convenient, but can certainly cause issues when it comes to expense visibility, monitoring usage and budget predictability.

A centralized purchasing approach can help you leverage your relationship with one supplier, simplify billing to one monthly invoice and provide the cost visibility most financial leaders are demanding in today's economy.

8.



Recycle empty printer cartridges to avoid landfill.

Too many office workers throw empty toner cartridges in the trash because they simply don't know what to do with them. In fact, it's estimated that 7 of 10 empty cartridges go directly to landfill where it takes up to 1,000 years for the cartridge casing and components to fully decompose.

If you're looking for a greener print strategy, ask your local Cartridge World about our complimentary printer cartridge recycling programs!

9.



Train employees on how to use printer features.

When is the last time your office equipment vendor provided a training session to your staff? We ask because it's estimated that 72% of "paid for" office technology capabilities are never used. It's also common knowledge that an untrained user will tend to be less productive and harder on equipment.

Properly trained office workers will be more productive, keep their information more secure and help to maximize the longevity of the equipment in your office.

10.

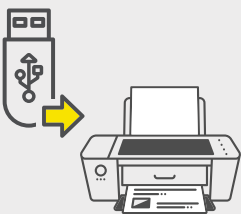

Set print driver defaults to desired settings.

Whether you're installing a new printer or looking to influence print behaviors on an existing printer, print drivers create an easy win.

Common print driver defaults include black & white printing vs color to save money and printing documents 2-sided vs single sided to reduce paper consumption. Look at the default settings on your print drivers to see what's available!

Putting it all together

- ✓ **Uncontrolled office print** volumes and costs **can be tamed** with the survival strategies presented and the **right printing partner**.
- ✓ **You don't have to do this alone**. Your local Cartridge World brings over **20 years of printing expertise** you can use to access, optimize and implement the right print strategy for your business.
- ✓ **Need help?** We're local and we're ready when you are.

About Cartridge World Business Printing Solutions

We **help businesses spend less time and money** on office printing so they can focus their resources on higher priority tasks. With **over 300 locations nationwide**, your local Cartridge World **provides brand name printing equipment, quality supplies** delivered to your door and friendly local service you can count on.

